

# APPC 0810T

8" TFT LED 4:3 Panel PC with Intel® Atom™ N270 1.6 GHz,  
touch screen, 1GB DDR2, 2xUSB, 2xCOM and VGA



## Main Features

- ♦ 4:3 8" fan-less LED Panel Computer
- ♦ Intel® Atom™ N270, Low Consumption CPU
- ♦ Fully flat 5-wired touch screen
- ♦ Dual GbE; 2nd display VGA
- ♦ USB x2/1xmini-PCIE/1xCF/2xCOMs, PS2 KB/MS
- ♦ Optional WiFi Module
- ♦ DDR2 1GB; 2.5" HDD bracket.
- ♦ IP65 protection front
- ♦ Mounting support Panel/Wall/Stand/VESA 75mmx75mm
- ♦ Wide range power input 11V~32V

## Product Overview

NEXCOM's Applied Panel PC incorporates a 4:3 LED touch screen panel, industrial motherboard for versatile industrial applications. The APPC 0810T is Fan-less Panel PC's which are based on the Atom™ N270 processor. The APPC 0810T is available in 8.0" LCD size with resolutions up to 800x600 (SVGA). Other features include built-in dual Ethernet and optional WiFi module and the slimmest x86 based touch terminal. With fully flat touch panel, the Panel PC can have IP65 front for industrial applications. The 8" APPC 0810T panel PC has 350nits brightness and can support resolutions up to VGA (800x600) including flush touch screen, 2GbE LAN, 2xCOMs, 2xUSB, PS2 KB/MS, Line-out and a wide range power inputs(11V~32V). With wide range power input from 11V~32V, APPC series can have telecom, industrial field and machine devices. With 2nd display by VGA, APPC series can hook 2nd display via VGA port with different content.

## Specifications

### Panel

- ♦ LED Size: 8", 4:3
- ♦ Resolution: SVGA, 800x600
- ♦ Luminance: 350cd/m2
- ♦ Contrast ratio: 400
- ♦ Viewing angle: 55(U), 65(D), 65(L), 65(R )
- ♦ Backlight:LED
- ♦ Touch screen: 5-line Resistive
- ♦ Touch light transmission: 80%
- ♦ Touch interface: USB

### System

- ♦ CPU: Intel® Atom™ N270 1.6GHz
- ♦ BIOS: Award 8M bit Flash BIOS
- ♦ I/O chip: ITE8712
- ♦ System memory: 1GB DDR2 support up to 2GB DDR2 400/533
- ♦ SSD: One CF socket by IDE support Type I/II Compact Flash Card
- ♦ Hard drive bay: Optional 2.5" SATA HDD
- ♦ Watchdog timer: Reset: 1 sec.~ 255 sec. and 1 min.~ 255 min.

- ♦ H/W status monitor: Monitoring system temperature, voltage, and cooling fan status.
- ♦ Expansion: Mini-PCle

### Rear I/O

- ♦ Serial port: 2xRS232
- ♦ Ethernet: 2xRJ45
- ♦ 2nd display: VGA port, 1xDB15
- ♦ Audio port: Line out, MIC in
- ♦ USB: 2xUSB 2.0
- ♦ PS2 Keyboard/Mouse
- ♦ Power Switch

### Audio

- ♦ AC97 codec: Realtek ALC888
- ♦ Audio interface: Connector: Line out, MIC in

### Ethernet

- ♦ LAN chip: Dual Realtek RTL8111C Gigabit LAN
- ♦ Ethernet interface: 10/100/1000 Based-Tx Fast Ethernet compatible

## Dimension Drawing

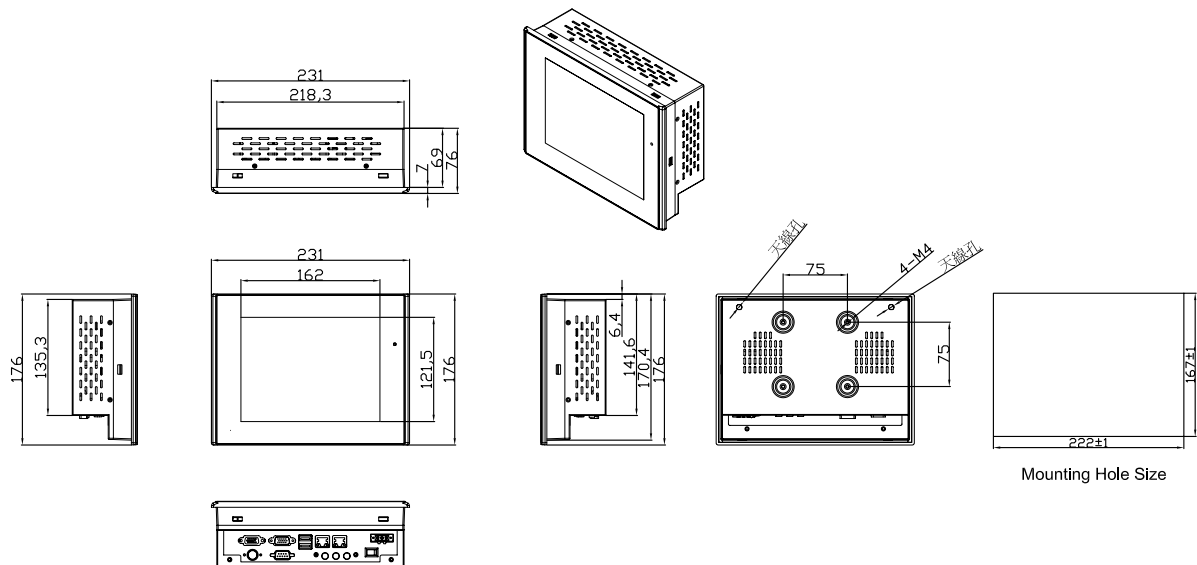

### Mechanical & Environment

- Color: Pantone black U
- IP protection: IP65 front
- Mounting: Panel/Wall/Stand/VESA 75mmx75mm
- Power input: 11V~32V
- Power adaptor: Optional AC power adaptor(+12V)
- Vibration:
  - Vibration Protection with Commercial SATA HDD only IEC 68 2-64 @ SINE condition 2 Grms @ sine, 5 ~ 500 Hz, 10 ct./min, 1hr/axis
  - Vibration Protection with Commercial SATA HDD only IEC 68 2-64 @ Random condition 0.3 Grms @ sine, 5 ~ 500 Hz, 10 ct./min, 1hr/axis
- Shock:
  - IEC 68 2-27
  - CompactFlash@: 50 G @ wall mount, half sine, 11 ms
  - HDD: 30 G @ wall mount, half sine, 16 ms
- Operating Temperature: 0 to 45°C
- Storage temperature: -20 to 75°C
- Operating humidity: 5%~90% relative humidity, non-condensing
- Dimension: 231x176x70mm
- Weight: 1.41Kg

### Ordering Information

- **Barebone**  
**APPC 0810T (P/N: 90IA0810T00X0)**  
 8" TFT LED Panel PC with Intel® Atom™ N270 1.6 GHz, touch screen, 1GB DDR2