



Main Features

- ♦ IP65 compliant plastic front bezel with flush panel by 5-wire touch screen
- ♦ Dual display input interface: analog VGA and DVI-D
- ♦ Shares identical appearance with APPC series
- ♦ Dual touch screen interface: RS232 and USB
- ♦ Ultra slim in depth
- ♦ OSD Multilanguage function

Product Overview

15" 4:3 LCD display APPD 1500T is based on a 5-wire resistive touch screen. It has 400 nits brightness and can support resolutions up to 1024 x 768. APPD 1500T is ideal for space-critical environments where systems and displays are kept apart. In addition, APPD 1500T adopts a flush panel design and has IP65 front panel. APPD 1500T provides prevailing video interfaces: VGA and DVI, supporting both digital and analog signals; touch screen can be connected with RS-232 or USB ports. Moreover, APPD 1500T supports 12~24V power input and offers panel mount and VESA mount, allowing users to choose the mounting method that meets their situation. APPD 1500T is the best solution for NEXCOM NISE fanless computer, NVIS security surveillance series and APPC panel PC when a second display is required.

Specifications

Panel

- ♦ LED Size: 15", 4:3
- ♦ Resolution: XGA 1024 x 768
- ♦ Luminance: 400cd/m²
- ♦ Contrast ratio: 700
- ♦ LCD color: 16.2M
- ♦ Viewing Angle: 60 (U), 80(D), 80(L), 80(R)
- ♦ Backlight: LED

Touch Screen

- ♦ 5-wire resistive (flush panel type)
- ♦ Light transmission: 80%
- ♦ Interface: USB and RS232

Rear I/O

- ♦ Touch screen interface port: RS-232 (1 x DB9)/USB Type A
- ♦ Video port: VGA (1 x DB15)/DVI-D (1 x DVI-I connector)
- ♦ DC power input connector: 3-Pin Phoenix terminal Blocks

OSD Function

- ♦ OSD keypad
- ♦ Multilanguage OSD

Mechanical & Environment

- ♦ Color: pantone black
- ♦ IP protection: IP65 front
- ♦ Mounting: panel/wall/stand/VESA 100mm x 100mm

- ♦ Power input: 12V~24VDC
- ♦ Power adapter: optional AC to DC power adaptor (+12V, 60W)
- ♦ Vibration:
IEC 68 2-64
2Grms @ sine, 5~500Hz, 1hr/axis (Operating)
2.2Grms @ random condition, 5~500Hz, 0.5hr/axis (Non-operating)
- ♦ Shock:
IEC 68 2-27
20G@wall mount, half sine, 11ms
Operating temperature: -5°C to 60°C
Storage temperature: -20°C to 75°C
- ♦ Operating humidity: 10%~90% relative humidity, non-condensing
- ♦ Dimension: 384.37 x 309.95 x 51.2mm
- ♦ Weight: 3.98Kg

Certifications

- ♦ CE approval
- ♦ FCC Class B

Ordering Information

- ♦ **APPD 1500T (P/N: 10IAD150000X0)**
15" XGA industrial 4:3 LED Backlight flush touch monitor with VGA and DVI-D input, 12~24VDC input, RS232 and USB touch screen Interfaces

Options

Dimension Drawing

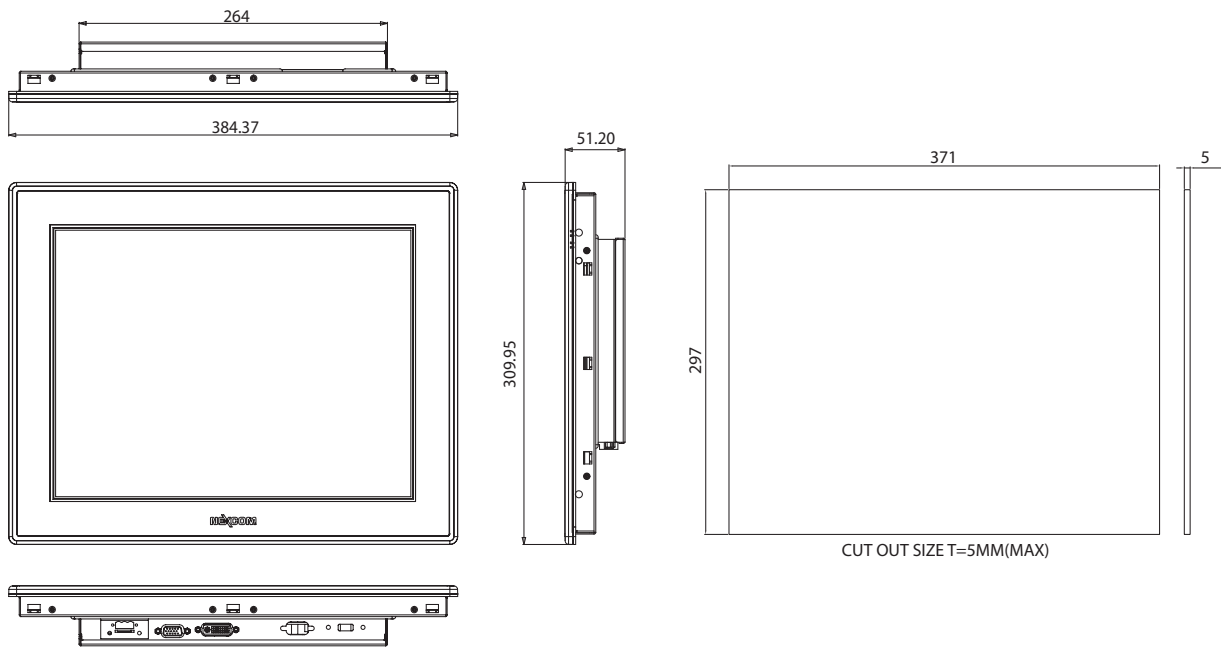

- 12V, 60W AC/DC power adapter w/o power cord
(P/N: 7400060019X00)
- 1.8m DVI-D male to DVI-D male Cable
(P/N: 60233DVI28X00)