

Main Features

- Intel® 2nd Generation Core™ Mobile Processors
- Intel® QM67/HM65 PCH
- 1x DDR3 SO-DIMM socket support non-ECC DDR3 800/1066/1333MHz up to 8GB
- Type 2 COM Express Module Support 6 Express Lanes, 32 bit PCI Interface, One IDE and Gigabit LAN

Product Overview

The ICES 267 is a COM Express Type 2 basic module featuring Intel® QM67/HM65 Platform Control Hub, which supports Intel® 2nd generation Core™ Mobile processors and one DDR3 SO-DIMM memory socket up to 8GB. The ICES 267 integrated with Intel® HD graphics or expands via PCI Express Graphic 1x 16 lane to carrier board; it also supports other display types include LFP or Dual channel LVDS. The high performance ICES 267 COM Express Module supports 4x SATA, 8x USB 2.0 and 6 PCIe x 1 lanes through the carrier board. It is compatible with ICEB 8050 carrier board and in-house designed ICES 267 F-kits from NEXCOM.

Specifications

CPU Support

- Support 2nd generation Intel® Core™ processor family, rPGA 988

Processor	i7-2710QE	i5-2510E	i3-2330E	Celeron® B810
# of Core	4	2	2	2
Clock Speed	2.1GHz	2.5GHz	2.2GHz	1.6GHz
Max. TDP	45W	35W	35W	35W

Main Memory

- One DDR3 1066/1333 MHz SO-DIMM, up to 8GB

Platform Control Hub

- QM67/ HM65

BIOS

- AMI System BIOS
- Plug and play support

Display

- Intel® HD graphics solution
- One PCI Express X 16 Lane down to the carried board
- Drive a standard progressive scan analog monitor with resolution up to 2048 x 1536 @ 60Hz
- Supports LVDS 18/24-bit & single/dual channel interface

Audio

- HD audio interface

On-board LAN

- Intel® 82579LM Gigabit Ethernet, support iAMT 7.0 (supported with QM67 only)
- Support boot from LAN, wake on LAN function
- Signals down to I/O board

COM Express Connector

- AB
VGA/ LVDS/ 8 x USB 2.0/ HD Audio/ 3 x SATA/ LAN/ GPIO/ LPC bus
One PCIe X4/ two PCIe X1/ SMBus (I2C)/ SPI BIOS
- CD
PCIe x 16/ IDE/ PCI

Power Requirements

- +12V, +5VSB, +3.3V RTC power

Dimensions

- 95mm (W) x 125mm (L)

Environment

- Board Level Operating temperatures: -15°C to 60°C
- Storage temperatures: -20°C to 80°C
- Relative humidity:
10% to 90% (operating, non-condensing)
5% to 95% (non-operating, non-condensing)

Block Diagram

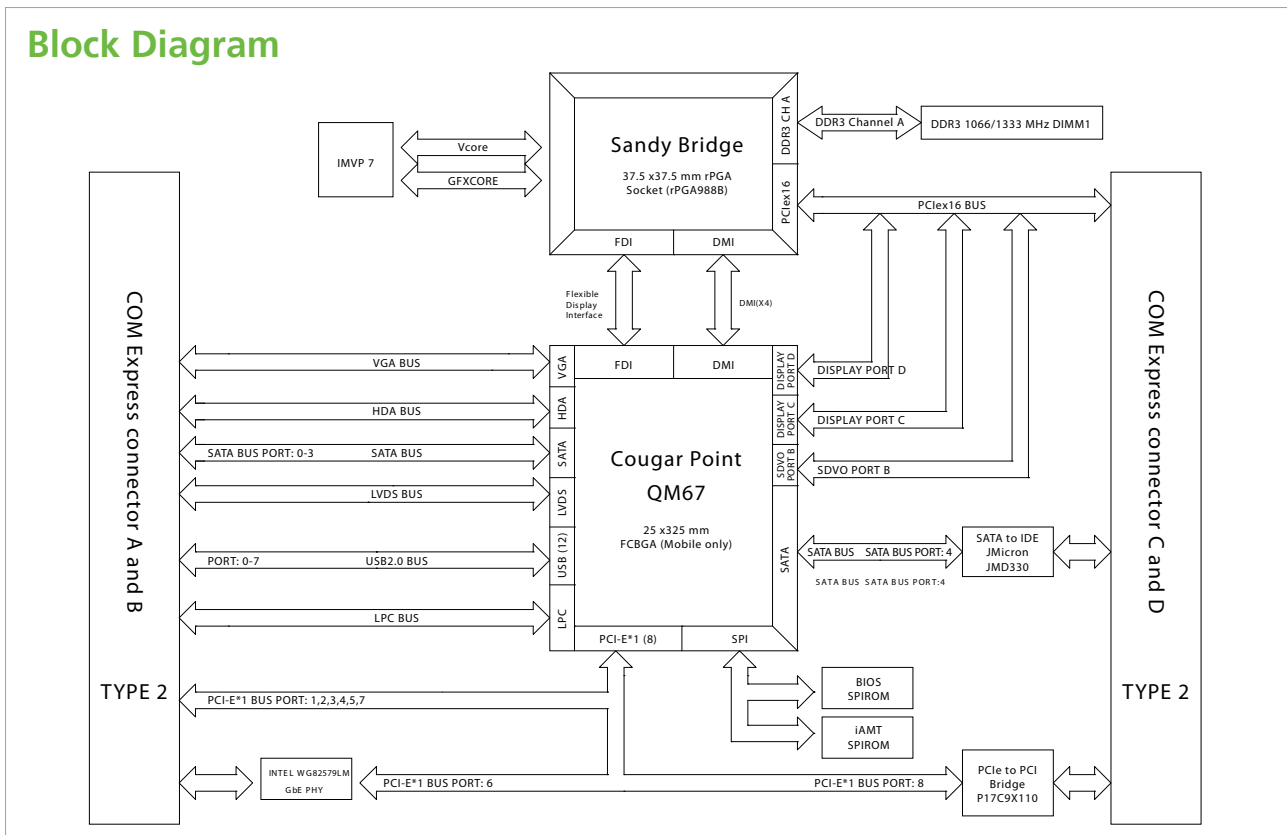

Certifications

- CE approval
- FCC Class A

Ordering Information

- ♦ **ICES 267 (P/N: 10K00026700X0)**
COM Express Type 2 basic module support Intel® Socket rPGA 988, 2nd generation Core™ mobile processor family, DDR3/ PCEex16/ PCI/ IDE/ GbE/ LVDS/ audio interface
- ♦ **ICEB 8050 (P/N: 10KB0805000X0)**
COM Express Type 2 evaluation board with PCIe/ PCI/ SATA/ CF/ IDE/ COM/ USB/ LVDS/ VGA/ LAN
- ♦ **ICES 267 F-Kit (P/N: 10K00026706X00)**
Active Fan Kits with heat-spreader, heat-sink and Cooling fan in-house designed for ICES267