

VTC 7120-D1

Intel® Celeron® Fanless In-Vehicle Computer with
Isolation GPIO, COM and Dual CAN Bus



Main Features

- ♦ Build-in Intel® Celeron® Processor 847E 1.1GHz
- ♦ Support two Ethernet LAN ports
- ♦ Removable 2.5" SSD tray and CFast slot
- ♦ CAN bus in support of SAE J1939 or J1708 up to dual
- ♦ Support two SIM card slots
- ♦ 9~36V wide range DC power input
- ♦ Smarter power management and low voltage protection
- ♦ Support isolation digital input and output
- ♦ Rugged fanless design to meet MIL standard
- ♦ Support Isolation RS-232 and RS-422/485

Product Overview

VTC 7120-D1, adopting the high performance processor, Intel® Celeron® is a new generation of VTC series. In addition to keep the advantage of existing VTC series, it offers dual LAN ports for redundancy, two high speed interface for storage, 2.5" SATA and CFast. The storage is easily accessible from the front side for maintenance concern. Furthermore, it offers the CAN bus for heavy duty truck such as SAE J1939/ J1708 and isolation digital input, output, RS-232 and RS-422/485. With the rich features, VTC 7120 can satisfy your demand in vehicle applications.

Specifications

CPU

- ♦ Intel® Core™ Celeron® Processor 847E 1.1GHz

Main Chipset

- ♦ QM67

Memory

- ♦ One 204-pin DDR3 1333MHz SO-DIMM slot (up to 8GB)

Expansion

- ♦ 1 x Mini-PCIe socket (PCIe + USB) for WLAN option
- ♦ 1 x Mini-PCIe socket (USB) x 1 for WWAN option
- ♦ 1 x Bluetooth module for option
- ♦ 1 x Built-in on board GPS module or optional GPS with dead reckoning

I/O Interface-Front

- ♦ 1 x Line-out, 1 x Mic-in
- ♦ 2 x SIM card socket
- ♦ 1 x System reset button
- ♦ 1 x USB 2.0 host type A connector
- ♦ 1 x Power button
- ♦ 1 x CFast with protection cover
- ♦ 1 x Accessible 2.5" SATA II SSD tray
- ♦ 2 x DB9 isolation RS-422/ 485
- ♦ 3 x DB9 isolation RS-232
- ♦ 4 x LED's for power, storage, WLAN/ WWAN and GPIO

I/O Interface-Rear

- ♦ 1 x 9~36VDC input with Ignition and 36W typical power consumption
- ♦ 1 x 12V/4A DC output, SMBus
- ♦ 1 x DB26 LVDS interface with 12V and USB2.0 or optional with DVI-D
- ♦ 1 x DB15 VGA
- ♦ 1 x DB9 RS-232 (COM1) or optional with CAN bus
- ♦ 1 x DB9 RS-422/ 485 (COM2)
- ♦ 1 x DB9 female connector for 4GPI and 4GPO
- ♦ Digital Input (source type; 0~30V)
- ♦ Digital Output (sink type; 20mA max)
- ♦ 2 x USB 2.0 host type A connector
- ♦ 2 x RJ45 with LEDs for 10/ 100/ 1000Mbps Ethernet
- ♦ 1 x Line-out, 1 x Mic-in
- ♦ 8 x Isolation digital inputs
- ♦ 8 x Isolation digital outputs
- ♦ 4 x Isolation differential analog inputs
- ♦ 1 x DB9 male connector for 2 CAN bus modules
- ♦ 1 x SMA-type GPS antenna connector
- ♦ 4 x Antenna hole reserved for SMA-type antenna connector (WWAN/ WLAN/ BT)

Power Management

- ♦ Selectable boot-up & shut-down voltage for low power protection by software
- ♦ Setting 8-level on/off delay time by software
- ♦ Status of ignition and low voltage status can be detected by software
- ♦ Support S3/ S4 suspend mode

Dimension Drawing

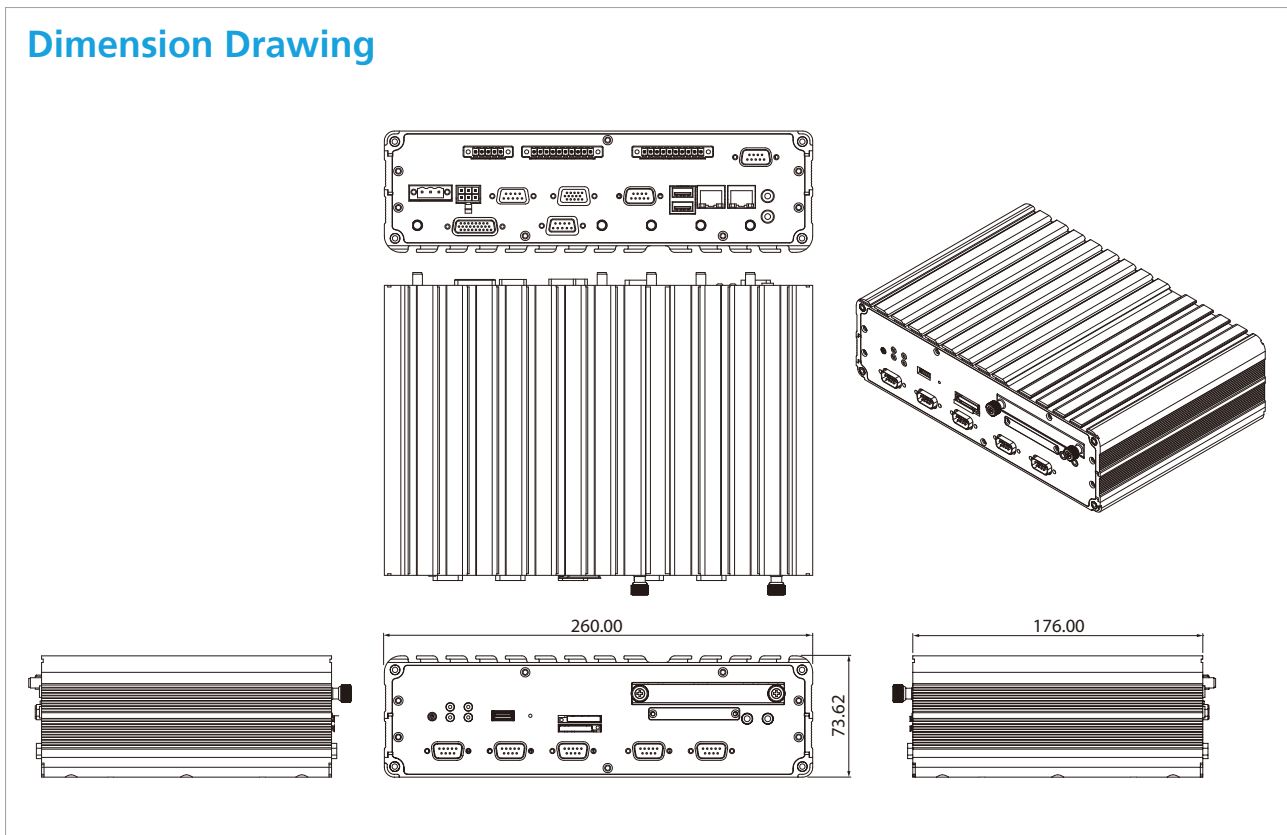

Operating System

- Windows XP/ WES2009
- WES 7E
- Win7 Pro for Embedded

Dimensions

- 260mm (W) x 176mm (D) x 73.6mm (H) (10.24" x 6.93" x 2.9")
- 4.5 Kg (9.92 Lb)

Construction

- Aluminum enclosure with fanless design

Environment

- Operating temperatures:
Ambient with air: -30°C to 50°C
- Storage temperatures: -35°C to 85°C
- Relative humidity: 10% to 90% (non-condensing)
- Vibration (random): 1g@5~500 Hz (in operation)
- Vibration:
Operating: MIL-STD-810F, Method 514.5, Category 20, ground vehicle- highway truck
Storage: MIL-STD-810F, Method 514.5, Category 24, integrity test
- Shock:
Operating: MIL-STD-810F, Method 516.5, Procedure I, trucks and semi-trailers=20g
Crash hazard: MIL-STD-810F, Method 516.5, Procedure V, ground equipment=75g

Standards/ Certifications

- CE approval
- FCC Class A

Ordering Information

♦ VTC7120-D1K (P/N: 10V00712002X0)

Intel® Celeron® 847E 1.1GHz, 2GB DDR3 SODIMM, LVDS/ VGA Output, 1 RS-232, 1 RS-422/485 with isolation DI/DO, COM and dual CAN bus

♦ Optional Accessories

Part No.	Description
10VD010000X0	VMD 1000-B 7" monitor w/ touch screen
10VD0100101X0	VMD 1001-B 7" Monitor w/ touch screen, VGA interface
10VD020000X0	VMD 2000-B 8" Monitor w/ touch screen
10VD0200200X0	VMD 2002-B 8" Monitor w/ touch screen, cable integration
10VK0071F00X0	VTK 71F, fan Kit
10VK0006013X0	Wireless mini card kit, Ralink 802.11b/g/n 2T2R, QCOM: Q802XKN5F, w/ antenna & cable (without assembly in NEXCOM)
10VK0WWAN01X0	Cinterion PHS8-P kit, Five bands, UMTS/HSPA (850/800, 900, 1900 and 2100 MHz), Quad-Band GSM w/ internal cable, antenna & packing (without assembly in NEXCOM)
10VK00GPS00X0	SKYTRAQ GPS + GLONASS, w/ antenna & cable
10VK0006007X0	Bluetooth kit, QCOM: QBTM400-01(V7), w/ antenna & cable (without assembly in NEXCOM)
7400120002X00	Power adapter FSP: 120-AAB (N09001), 120W 19V/ 6.3A
60233SAM03X00	Internal cable for GSM/WLAN/GPS antenna connection MOQ: 20 pcs
60233SAM05X00	GPS antenna/ 5m/ SMA180P
60233SAM07X00	GSM/ GPRS antenna, SMA, support 850, 900, 1800, 1900
60233SMA30X00	GPS+GSM combo antenna 5M/ SMA180P
60233SAM17X00	GPRS/ UMTS/ HSDPA antenna, SMA, support 850, 900, 1800, 1900 and 2100 MHz
60233SAM07X00	GSM/ GPRS antenna, SMA, support 850, 900, 1800, 1900
60233SMA30X00	GPS+GSM combo antenna 5M/ SMA180P
60233SAM17X00	GPRS/ UMTS/ HSDPA antenna, SMA, support 850, 900, 1800, 1900 and 2100 MHz